

AIR COOLED DIESEL ENGINES

12.0-26.0 KW

STANDARD EQUIPMENT

Electric starting with 12 V starter motor and alternator
Remote throttle
Oil pressure switch
Combined manifold and exhaust muffler
Engine feet
Fuel lift pump
Counter-clockwise rotation on power take-off side
Automatic extra fuel device
Use, maintenance and spare parts booklet
Oil bath air filter
Manual control accelerator
Power take-off on flywheel (KD 625/2 - 9 LD 625/2; KD 626/3 - 11 LD 626/3)
Power take-off on crankshaft (KD 330/2 - 25 LD 330/2; KD 425/2 - 25 LD 425/2; KD 477/2 - 12 LD 477/2)
Fuel tank with filter
Guard for belt (KD 626/3 - 11 LD 626/3)

ACCESSORIES ON DEMAND

Different guards according to use
Range of alternative alternators and 24 V
Compression release
Flanges
Dry air filter
External fuel filter
Clutches
Hydraulic pump adapters
Range of fuel tanks of various sizes
Range of flywheels for various clutches
Mufflers and exhaust pipes
Controls
Pulleys
Oil cooler (KD 625/2 - 9 LD 625/2; KD 330/2 - 25 LD 330/2; KD 425/2 - 25 LD 425/2; KD 626/3 - 11 LD 626/3)
Crank starter (KD 625/2 - 9 LD 625/2)
Keyswitch panel



KD 477/2 12 LD 477/2

QUICK SPECIFICS

2
CYLINDER

22.8 | **16.8** @ 3600 rpm
HP | kW

55.0 @ 2100 rpm
Nm

[Power & torque N curve - 80/1269/CE e-ISO 1585]



DATA

DIMENSIONS (mm)

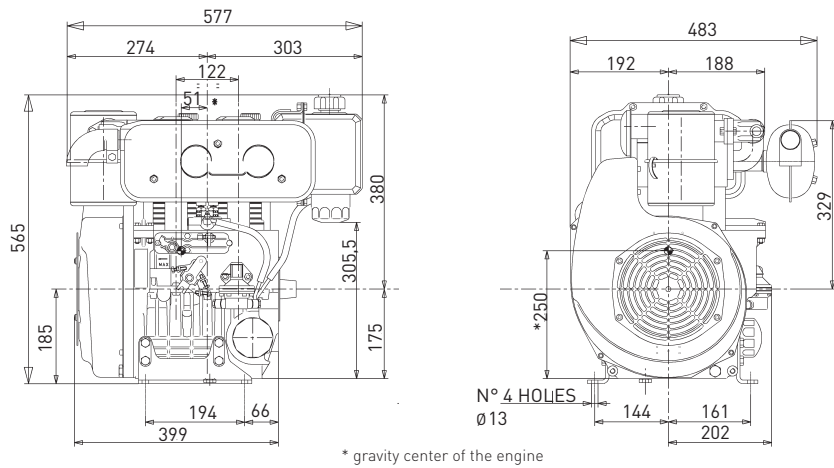

PERFORMANCE CURVES (IFN- ISO 3046 AND ISO 14396)

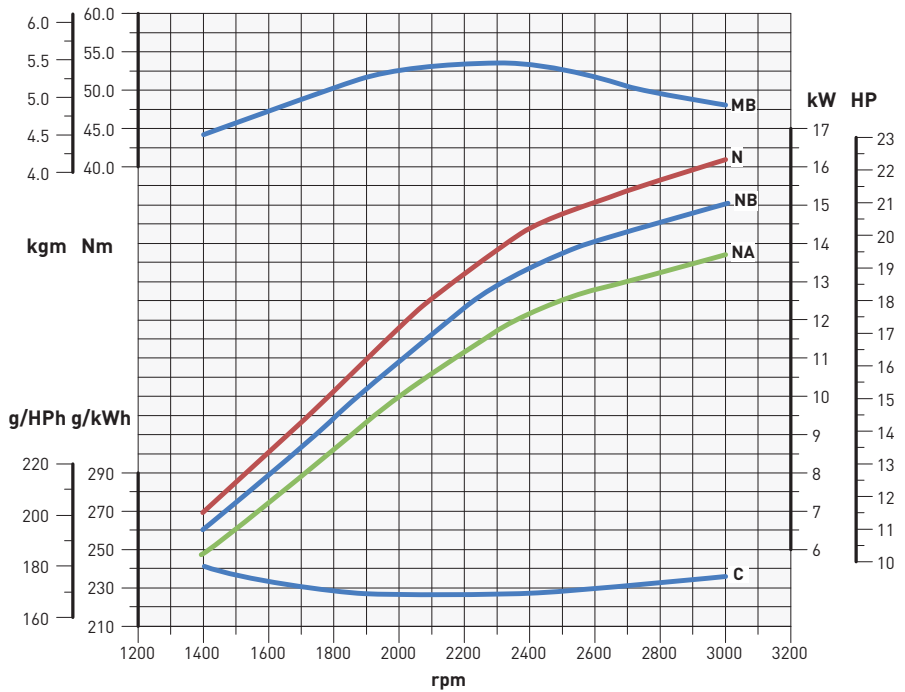

N - Power curve - 80/1269/CE E-ISO 1585
NB - Power curve - ISO 3046/1 -IFN
NA - Power curve - ISO 3046/1 - ICXN
MB - Torque curve - (NB curve)
C - Specific fuel consumption - (NB curve)

Power ratings refer to engines equiped with air filter, standard muffler, after being run in and in ambient conditions of 25°C and 1 bar. Power levels drop by 1% every 100m altitude and by 2% every 5°C above 25°C.

APPLICATIONS SPECS

KD 330/2 - 25 LD 330/2 ; KD 425/2 - 25 LD 425/2

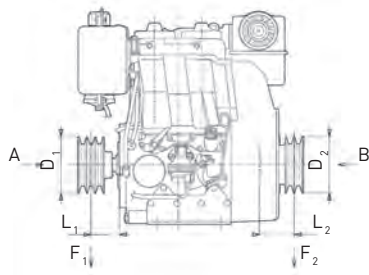

Minimum pulley diameters for belt drive

$$330/2: \quad D_1 \text{ (mm)} \geq 585 [49 + L_1(\text{mm})] \frac{N \text{ (kW)}}{n \text{ (rpm)}} \quad D_2 \text{ (mm)} \geq 1030 [31 + L_2(\text{mm})] \frac{N \text{ (kW)}}{n \text{ (rpm)}}$$

$$425/2: \quad D_1 \text{ (mm)} \geq 700 [45 + L_1(\text{mm})] \frac{N \text{ (kW)}}{n \text{ (rpm)}} \quad D_2 \text{ (mm)} \geq 1540 [17 + L_2(\text{mm})] \frac{N \text{ (kW)}}{n \text{ (rpm)}}$$

Max intermittent axial load in both directions A - B = 300 kg

KD 477/2 - 12 LD 477/2

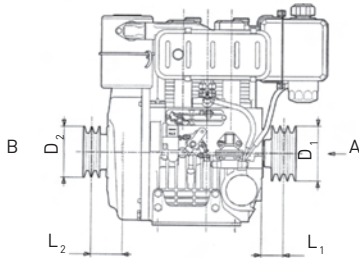

Minimum pulley diameters for belt drive

$$D_1 \text{ (mm)} \geq 220 [78 + L_1(\text{mm})] \frac{N \text{ (kW)}}{n \text{ (rpm)}} \quad D_2 \text{ (mm)} \geq 196 [150 + L_2(\text{mm})] \frac{N \text{ (kW)}}{n \text{ (rpm)}}$$

Max intermittent axial load in both directions A - B = 350 kg

KD 625/2 - 9 LD 625/2

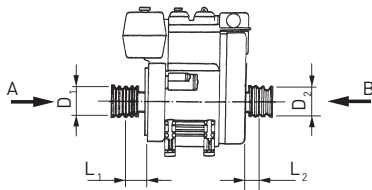

Minimum pulley diameters for belt drive

$$D_1 \text{ (mm)} \geq 136 [162 + L_1(\text{mm})] \frac{N \text{ (kW)}}{n \text{ (rpm)}} \quad D_2 \text{ (mm)} \geq 204 [260 + L_2(\text{mm})] \frac{N \text{ (kW)}}{n \text{ (rpm)}}$$

Max intermittent axial load in both directions A - B = 300 kg

KD 626/3 - 11 LD 626/3

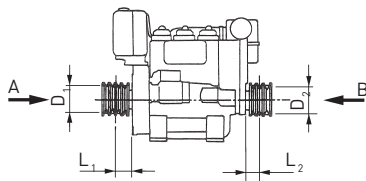

Minimum pulley diameters for belt drive

$$D_1 \text{ (mm)} \geq 100 [185 + L_1(\text{mm})] \frac{N \text{ (kW)}}{n \text{ (rpm)}} \quad D_2 \text{ (mm)} \geq 113 [169 + L_2(\text{mm})] \frac{N \text{ (kW)}}{n \text{ (rpm)}}$$

Max intermittent axial load in both directions A - B = 300 kg

AVAILABLE FLANGES*

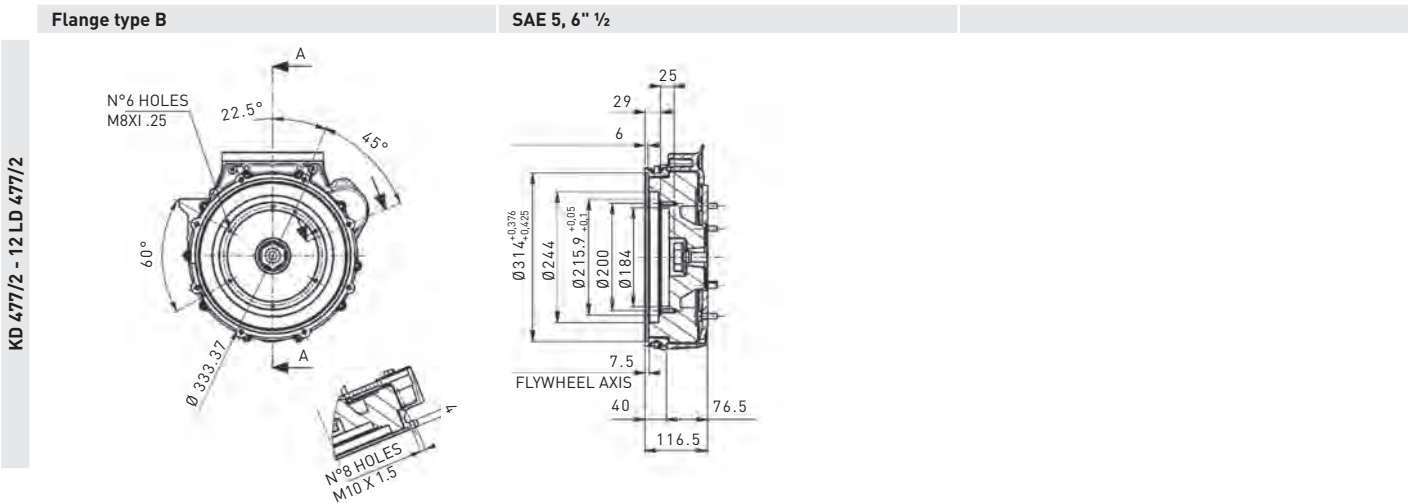
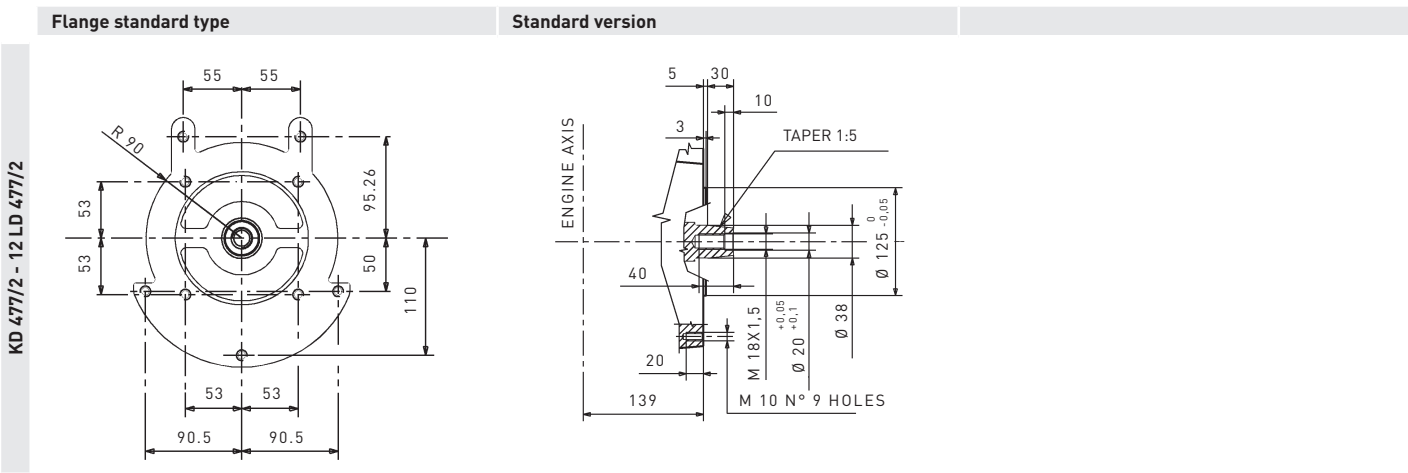
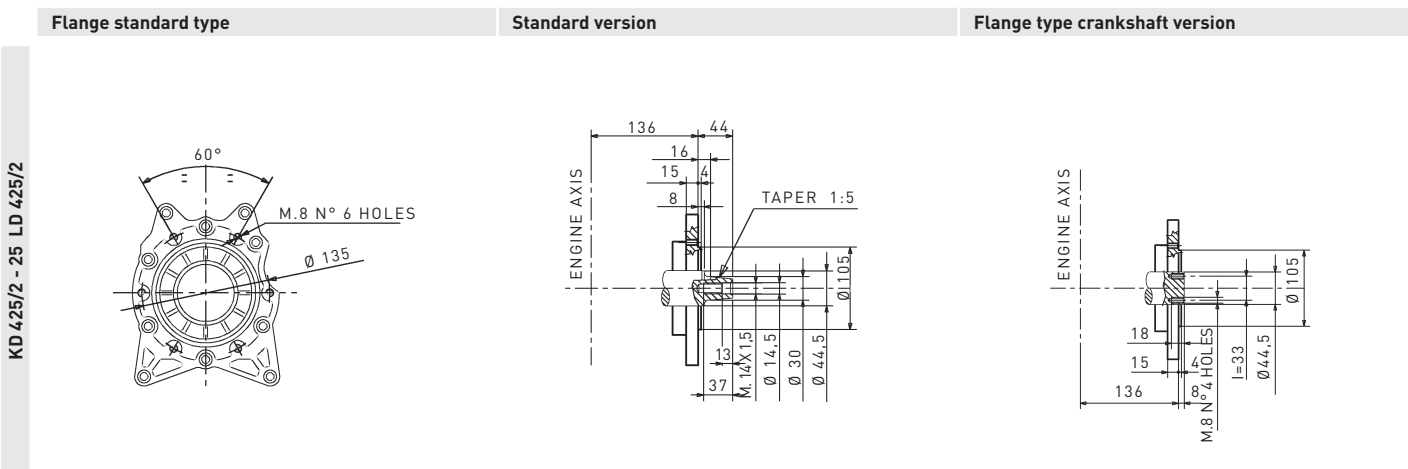
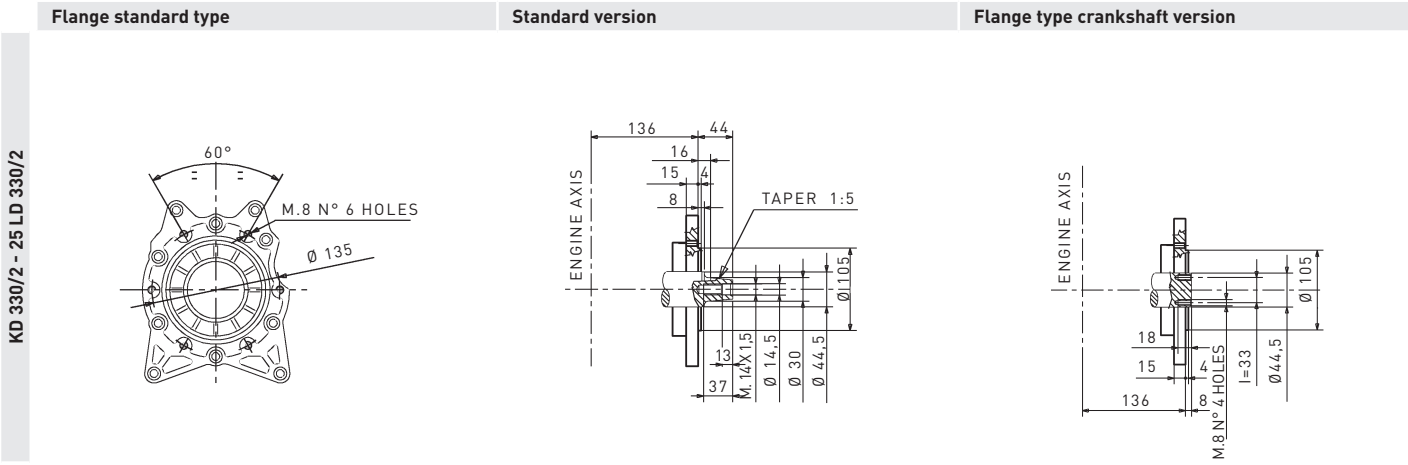

Model		KD 477/2 12 LD 477/2	KD 625/2 9 LD 625/2	KD 626/3 11 LD 626/3	
Engine specs	4 stroke air cooled diesel engine	•	•	•	
	Direct injection	•	•	•	
	Mechanical fuel lift pump	•	•	•	
	Forced lubrication with oil pump	•	•	•	
	Full flow oil filtration	•	•	•	
	Torque regulator	•	•	•	
	Centrifugal speed governor	•	•	•	
	Crankcase in die-cast aluminum	•	•	•	
	Electric starting	•	•	•	
	Counter-clockwise rotation (from power take-off side)	•	•	•	
	Aluminum alloy independent heads	•	•	•	
	Independent cast iron cylinders	•	•	•	
	Automatic extra fuel starting device	•	•	•	
	Air cooled by fan	•	•	•	
	Power take-off on crankshaft	•	-	-	
Power take off on Flywheel	-	•	•		
Technical features	Cylinder	2	2	3	
	Bore (mm)	90	95	95	
	Stroke (mm)	75	88	88	
	Engine displ (cm ³)	954	1248	1870	
	Injection system	DI	DI	DI	
	Compression ratio	19:1	17.5:1	17:1	
Performance	Emission compliance	ECE R 24	ECE R 24	EPA TIER4	
	Rating (kW/HP) N (80/1269/CEE)ISO 1585 NB ISO 3046 IFN NA ISO 3046 ICXN	16.8/22.8 15.7/21.4 14.5/19.7	- 18.8/25.5 16.9/23.0	- 16.5/22.4 15.0/20.4	- 26.0/35.4 23.4/31.8
	Max torque (Nm@rpm)	55.0@2100	67.0@2000	52.5@3000	102.0@2000
	Min idling speed (rpm)	1000	1000±1100		800-900
Fuel compatibility	EN 590	•	•	•	
	No 1 Diesel (US) - ASTM D 975-09 B - Grade 1-D S 15	•	•	•	
	No 1 Diesel (US) - ASTM D 975-09 B - Grade 1-D S 500	•	•	•	
	No 2 Diesel (US) - ASTM D 975-09 B - Grade 2-D S 15	•	•	•	
	No 2 Diesel (US) - ASTM D 975-09 B - Grade 2-D S 500	•	•	•	
	ARCTIC EN 590/ASTM D 975-09 B	•	•	•	
	High Sulfur Fuel < 5000 ppm (< 0.5%)	•	•	•	
	High Sulfur Fuel > 5000 ppm (> 0.5%)	•	•	•	
	Military NATO Fuels F34 - F35 - F44 - F63 - F64 - F65 *	•	•	•	
	Military US Fuels JP5 - JP8 (AVTUR) *	•	•	•	
Civil Jet Fuels Jet A/ A1*	•	•	•		
Service features	Fuel tank capacity (l)	7	10	15	
	Oil sump capacity (l)	2.5	2.8	5	
	Oil consumption (kg/h)	0.011	0.013	0.017	
	Oil change interval std/synthetic (hr)	200 **	250 **	250 **	
	Oil filter change interval std/synthetic (hr)	200 **	250 **	250 **	
	Valve adjustment	300	250	500	
Physical characteristics	H x L x W (fan excluded) (mm)	565x577x483	599x633x557	686x770x495	
	Dry weight (kg)	78	115	170	
	Daily service points - positions	1 side service	1 side service	1 side service	
	Ambient operating temps (°C)	-10° +45° ***	-10° +45° ***	-10° +45° ***	
	Gradeability-all round (intermittent-30 min) (deg)	25°	25°	25°	
	Gradeability-all round (peak value-1min) (deg)	35°	35°	35°	
	Cap. of air required for correct combustion @3600 (l/min)	1500/1220	1600 (@3000)	2400 (@3000)	
	Cap. of air required for correct cooling @3600 (l/min)	15800/13200	26300 (@3000)	38000 (@3000)	
Lubrication	Oil type	SAE 15 W-40 API CF4/SG ACEA B2/E2	SAE 10 W-40 API CF4/SG ACEA B2/E2	SAE 15 W-40 API CF4/SG ACEA B2/E2	

* With restrictions ** According to operating conditions ***-32°C on demand